

Component 1 mark scheme – 1DT0/1F

Section A – Core content

Question number	Answer	Mark
1 (a) (i)	Any one property from: <ul style="list-style-type: none"> • hard (1) • durable (1) • close grained (1) • tough (1) • non-toxic materials (1) 	(1)

Question number	Answer	Mark
1 (a) (ii)	Any one property from: <ul style="list-style-type: none"> • good heat insulator (1) • absorbs odours (1) • soft (1) • maintains body heat / warmth (1) 	(1)

Question number	Answer	Mark
1 (a) (iii)	Any one property from: <ul style="list-style-type: none"> • good heat insulator (1) • very good impact resistance (1) • semi-rigid (1) 	(1)

Question number	Answer	Additional guidance	Mark
1 (a) (iv)	Any one property from: <ul style="list-style-type: none"> • ductile (1) • malleable (1) • good conductor of heat (1) • corrosion resistance (1) • waterproof (1) • compressive / tensile / bending strength (1) 	Do not accept unqualified response in relation to strong or strength.	(1)

Question number	Answer	Mark
1 (b)	<p>Any one explanation that includes a disadvantage (1) and a linked justification of that disadvantage (1).</p> <ul style="list-style-type: none"> • It could give you an electric shock if you touched a bare wire / connection (1) which could result in a burn / electrocution (1) • There might be a power cut (1) which results in power loss / lights out / loss of computer data (1) • Not available in remote / rural areas (1) so it reduces accessibility (1) 	(2)

Question number	Answer	Additional guidance	Mark
1 (c)	<p>A calculation that includes:</p> <ul style="list-style-type: none"> • correct working (1) • correct answer to whole number (1) <p>Method:</p> $\frac{5.69-1.12}{5.69} \times 100 \quad (1)$ <p>80% (1)</p>	<p>Award full marks for correct numerical answer without working.</p> <p>Allow for ECF if candidate gets part of calculation wrong.</p>	(2)

Question number	Answer	Mark
2 (a)(i)	<p>One name from:</p> <ul style="list-style-type: none"> • eccentric (1) • circular (1) 	(1)

Question number	Answer	Mark
2 (a)(ii)	<p>Any one description that includes an accurate statement about movement of the bird (1) and a linked justification of that statement (1).</p> <ul style="list-style-type: none"> • The bird will pivot / rotate around the axle (1) like a pecking motion (1) • The bird will rock backwards and forwards (1) as the follower goes up and down (1) 	(2)

Question number	Answer	Mark
2 (a)(iii)	<p>Any one explanation that includes an effect of change in the cam (1) and a linked justification of that effect (1).</p> <ul style="list-style-type: none"> • The bird will rise gently (1) before dropping suddenly (1) 	(2)

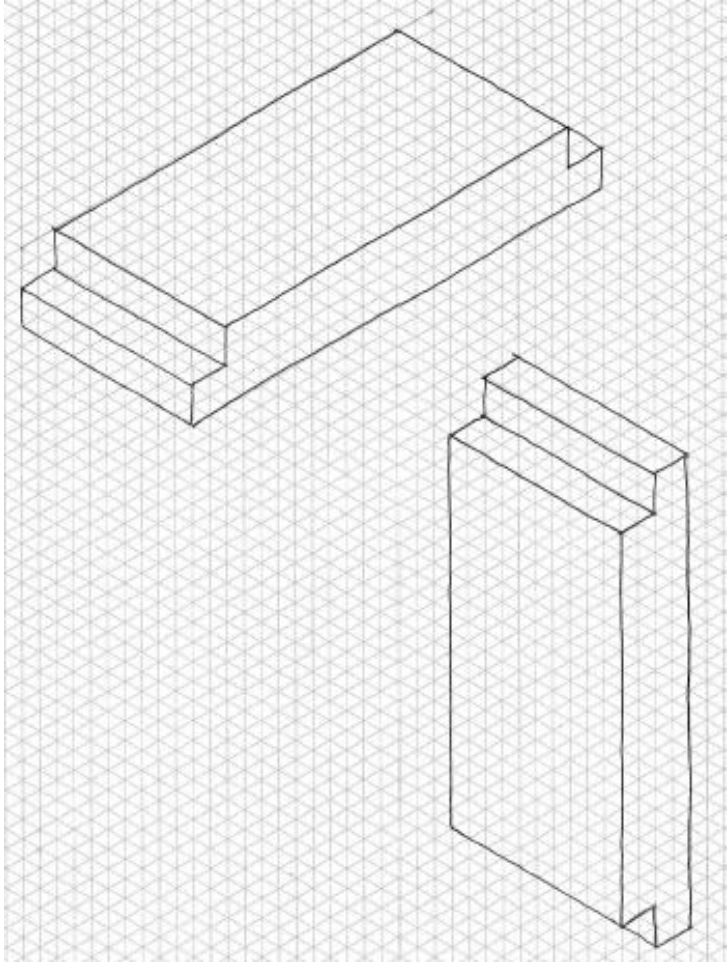
Question number	Answer	Mark
2 (b)	<p>An isometric drawing that includes an image drawn with a ruler or free hand. Marks to be awarded for the following.</p> <ul style="list-style-type: none"> • Accurate setting out of the straight edges to the correct shape (1) • Correct height (1) • Correct width (1) • Correct dimensions of the rebate (1) 	(4)

Question number	Answer	Mark
3 (a)	<p>Any one property from:</p> <ul style="list-style-type: none"> • durable (1) • hard wearing (1) • abrasion resistance (1) • tear resistance (1) 	(1)

Question number	Answer	Mark
3 (b)	<p>Any one explanation that includes a reason for batch production (1) and a linked justification of that reason (1).</p> <ul style="list-style-type: none"> • The supply of old pairs of jeans might be limited (1) therefore the incoming supply of raw materials may restrict the level of production (1) • Their ability to sell large levels of stock might be limited (1) therefore they would not want to manufacture stock they could not sell (1) • The workshop capacity may be limited (1) allows other products to be produced by the company (1) • Less storage of raw materials (1) so saving space (1) 	(2)

Question number	Answer	Mark
3 (c)	<p>Any one explanation that includes an advantage of government funding for new business start-ups (1) and a linked justification of that advantage (1).</p> <ul style="list-style-type: none"> • The interest rates are likely to be lower / fixed (1) which means it is a cheaper way to borrow money / fund the start-up in comparison to a traditional bank loan (1) • Business mentors are often associated with government backed loans (1) who can provide valuable guidance and assistance in the early stages of a new business (1) • The business owner does not have to find a guarantor (1) making it easier for people from different backgrounds to start a business (1) 	(2)

Question number	Answer	Additional guidance	Mark
3 (d)	<p>A calculation that includes:</p> <p>correct working (1)</p> <p>correct answer to nearest whole number (1)</p> <p>Method:</p> <p>$144 \times 10^6 \times 1.08 \times 1.08 = 1.679616$ million / 1.679616 (1)</p> <p>£170 million (1)</p>	<p>Award full marks for correct numerical answer without working.</p> <p>Allow for ECF if candidate gets part of calculation wrong.</p>	(2)

Question number	Answer	Mark
3 (e)	<p>Any two explanations that includes a reason for using renewable energy sources (1) and a linked justification of that reason (1).</p> <ul style="list-style-type: none"> • Renewable energy sources help to reduce a factory's carbon footprint (1) therefore it gives the factory 'greener' credentials / saves finite resources (1) • Once the factory has paid for the installation costs (1) the energy used is free / reduces operating costs (1) • The factory / unit might be in an area that cannot be connected to a National grid supply (1) therefore it is only possible to use an alternative supply such as renewable sources which will be available (1) 	(4)

Question number	Answer	Mark
4 (a)(i)	<p>Any one explanation that includes a valid reason for using aluminium (1) and a linked justification of that reason (1)</p> <ul style="list-style-type: none"> • Aluminium is malleable (1) which means it can be pressed into shape easily without tearing / ripping / edges folded over the keep the lid in place (1) • Aluminium is ductile (1) which means it can be formed / rolled out into long thin sheets ready to be pressed into shape (1) • Aluminium has a high lustre surface finish / shiny (1) and will reflect the heat of the hot food / retain the heat inside the container (1) • Aluminium is inert (1) and therefore will not contaminate the food (1) • Aluminium is relatively light weight (1) and therefore does not add unnecessary weight (1) • Aluminium is waterproof (1) and therefore stops any liquid seeping through the package (1) 	(2)

Question number	Answer	Mark
4 (a)(ii)	<p>Any one explanation that includes an advantage of using solid white board (1) and a linked justification of that advantage (1)</p> <ul style="list-style-type: none"> • Excellent surface finish (1) which means it can be printed on / branded with a company's logo (1) • Can be coated / have a foil back applied to it (1) which means the heat will be reflected / retained within the food container (1) • It is a rigid / quite stiff material (1) which means the foil container can be folded down onto / over the lid without it bending / flexing retains the shape of the container (1) • Lid can be die cut in bulk (1) reducing costs (1) 	(2)

Question number	Answer	Additional guidance	Mark
4 (b)	<p>A calculation that includes:</p> <p>Correct working (1)</p> <p>Calculation of correct ratio 18:38 (1)</p> <p>Method:</p> <p>$22 / 56 \times 18 = 7.071429$ million tonnes (1)</p> <p>= 7.07 million tonnes (1)</p>	<p>Award full marks for correct numerical answer without working.</p> <p>Allow for ECF if candidate gets part of calculation wrong.</p>	(2)

Question number	Indicative content	Mark
4 (c)	<ul style="list-style-type: none"> • The environmental damage caused to the landscape / countryside in China will be huge • Energy consumption will be high in China as the process requires a lot of energy / related pollution issues • Transportation of aluminium around the world • Europe does not produce any aluminium and so they have to import / jobs / transport costs / pollution • Countries could be encouraged to recycle more rather than to make aluminium from new / energy dependent • Companies could be encouraged to recycle / more / financial incentives paid for scrap aluminium 	(6)

Level	Mark	Descriptor
	0	
Level 1	1 - 2	<ul style="list-style-type: none"> • Attempts to interrogate and deconstruct information but connections and logical chains of reasoning are flawed. • An unbalanced appraisal of the information/issues, containing judgements that show a limited awareness of the interrelationships between factors or competing arguments.
Level 2	3 - 4	<ul style="list-style-type: none"> • Interrogates and deconstructs information and provides some connections and logical chains of reasoning. • A balanced appraisal of the information/issues, containing judgements that show an awareness of the interrelationships between factors or competing arguments.
Level 3	5 - 6	<ul style="list-style-type: none"> • Interrogates and deconstructs information and provides sustained connections and logical chains of reasoning. • A well-balanced appraisal of the information/issues, containing judgements that show a thorough awareness of the interrelationships between factors or competing arguments.

Section B – Timbers

Question number	Answer	Mark
5 (a)	<p>Marks will be awarded for understanding of design and technology, not graphical skills.</p> <p>Notes and/or sketches that include:</p> <ul style="list-style-type: none"> • a method of showing (1) that the trophy is for the winner (1) e.g. engraved / burnt into the timber / vinyl stickers to show No 1 / winner / 1st / 1 stuck to the top of the ball / laser cut into the ball / wooden base • protection of the bottom of the wooden base (1) when being placed on a hard surface (1) e.g. felt glued onto the base / rubber feet / soft pads • the winners name shown (1) updated annually (1) e.g. screwed on plaque /hand painted /old name on plaque removed. <p>Example of candidate response.</p> <p>Annotated notes: Vinyl sticker '1' is cut out and applied to the tee. A brass plaque can be engraved and fixed to the base with 4 small screws therefore easily changed. Felt glued onto the base of the trophy which is soft and will protect the base nor will it damage the surface it is placed on.</p>	(6)

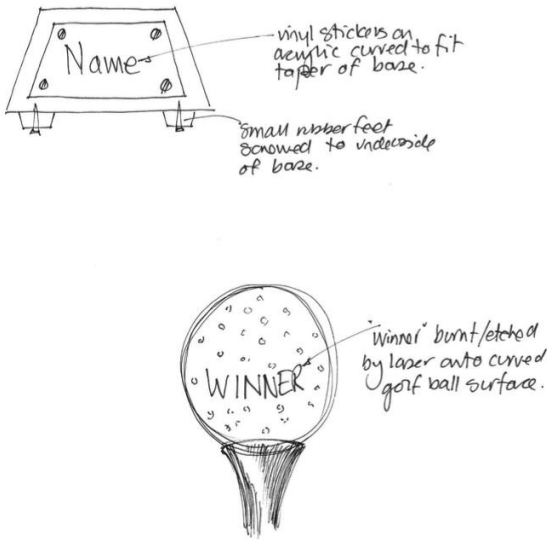
Question number	Answer	Mark
5(a) Cont	<p>Example of candidate response:</p>  <p>vinyl stickers on acrylic curved to fit taper of base.</p> <p>small rubber feet screwed to underside of base.</p> <p>Winner burnt/etched by laser onto curved golf ball surface.</p>	

Question number	Answer	Mark
5(b)	<p>Any two explanations that include a way (1) and a linked justification of that way (1).</p> <ul style="list-style-type: none"> • The two cubes have different numbers on all the faces (1) so as they are rotated round they show the correct two numbers for the specific date (1) • The long blocks at the bottom show the month of the year (1) and as the month changes the blocks are simply rotated (1) • It might be a bit confusing to work out what the date number is (1) because of the numbers being shown on the top of the cubes (1) 	(4)

Question number	Answer	Mark
6 (a)	<p>Any two advantages includes a reason (1) and a linked justification (1)</p> <ul style="list-style-type: none"> • It will save timber being wasted (1) which will reduce the overall cost of the timber needing to be purchased (1) • Different pieces / types of timber / colours can be glued together (1) to make it more visually appealing / aesthetically attractive (1) • Short ends / pieces of timber can be used (1) which will use up scraps / pieces that might otherwise have been thrown away / burnt / send to landfill (1) • Other materials and/or components can be included (1) making the candle holder more versatile / easier to use (1) 	(4)

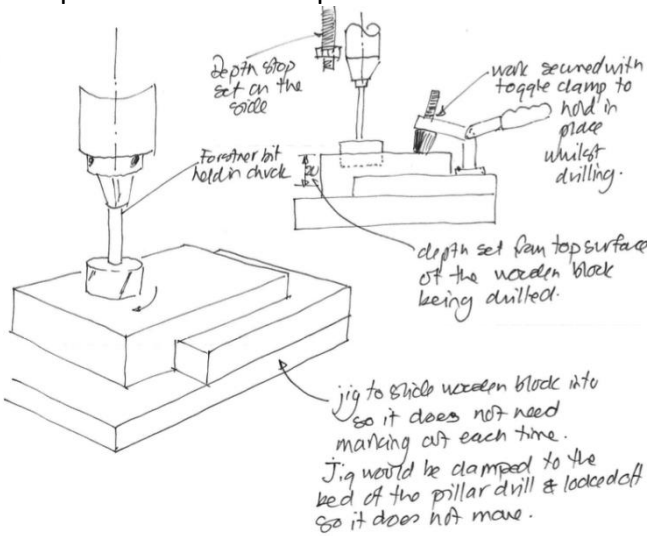
Question number	Answer	Additional guidance	Mark
6 (b)	<p>Marks will be awarded for understanding of design and technology, not graphical skills.</p> <p>Notes and/or sketches that include:</p> <ul style="list-style-type: none"> • Putting / securing the forstner bit in the chuck / chuck key (1) • The clamping / setting up of the work /potential use of jigs / setting a datum point / depth (1) • Setting up the depth stop (1) • Securing the bed of the machine to ensure it will not move / change position during the drilling process(1) <p>Example of candidate response:</p>  <p>Annotations in the diagram:</p> <ul style="list-style-type: none"> depth stop set on the side Forstner bit held in chuck work secured with toggle clamp to hold in place whilst drilling. depth set from top surface of the wooden block being drilled. jig to slide wooden block into so it does not need marking out each time. Jig would be clamped to the bed of the pillar drill & locked off so it does not move. <p>Annotated notes: Depth stop set on the side. Forstner bit held in chuck. Work secured with toggle clamp to hold in place whilst drilling. Depth set from top surface of the wooden block being drilled. Jig to slide work into so it does not need marking out each time. Jig would be clamped to the bed of the pillar drill and locked off so it does not move.</p>	Do not accept anything related to using a hand / cordless drill or the drilling process itself.	(4)

Question number	Answer	Mark
6 (c)	<p>Any one explanation that includes a reason for using PVA (1) and a linked justification for that reason (1).</p> <ul style="list-style-type: none"> • PVA is a general purpose woodworking adhesive (1) and is ideal for joining wood to wood (1) • PVA allows you to move the two pieces over each other if they are not lined up correctly (1) unlike some other adhesives which bond on contact (1) • PVA will go off / cure under pressure within 4 hours (1) which speeds up manufacturing time (1) • Can be used 'off the shelf' (1) without mixing (1) 	(2)

Question number	Answer	Mark
6 (d)	<p>Any two explanations that include a method (1), plus two linked justifications of that method (1) + (1).</p> <ul style="list-style-type: none"> • It could be laminated (1) from several thinner sections of flexi ply / veneers over a former / vacuum bag / PVA / steam bent (1) which means minimal material is required to form the shape (1) • It could be cut from a solid piece of timber (1) which would enable a fast / quicker production time (1) because no time would be lost to waiting for glue to dry (1) 	(6)

Question number	Answer	Mark
7 (a)	<p>One correct geographical forest region given from:</p> <ul style="list-style-type: none"> • European (1) 	(1)

Question number	Answer	Mark
7 (b)	<p>Any two explanations that include a reason for using varnish rather than paint (1) plus a linked justification for the reason (1)</p> <ul style="list-style-type: none"> • Varnish will allow the grain of the oak to be seen (1) unlike paint which will hide it / cover it up (1) • Oak has a distinctive grain pattern / colour (1) and as such it deserves to be shown off / enhanced rather than covered up with paint (1) • Oak is a relatively expensive material (1) and as such if you want a painted finish you could use a cheaper timber like pine (1) 	(4)

Question number	Answer	Additional guidance	Mark
7 (c)	<p>A calculation that includes:</p> <ul style="list-style-type: none"> • Conversion of units • Calculation of flat surface area of two large sides ($100 \times 900 \times 2 = 180,000$) (1) • Calculation of semi-circular surface area ($50 \times 50 = 2500 \times 3.142 = 7855 \times 2 / 2 = 7,855$) (1) • Calculation of surface area on the edges ($15 \times 900 \times 2 = 27000$) ($100 \times 15 = 1500$) ($2 \times 3.142 \times 50 \times 15/2 = 2356.5$) (Total = 30,856.5) (1) • Total surface area calculation for 6 pieces ($180,000 + 7,855 + 30,856.5 \times 6 = 1,312,269$ mm² or 1.312 m²) (1) • Calculation of volume ($1000 / 12 \times 1.312 = 109.36$ ml) (1) 	<p>Do not award the final mark if the final answer is in litres.</p> <p>Award full marks for correct numerical answer without working.</p> <p>Allow ecf if candidate gets part of calculation wrong.</p>	(5)

Question number	Answer	Mark
7 (d)	<p>Any two explanations that includes a working property (1), plus two linked justifications of that working property (1) + (1).</p> <ul style="list-style-type: none"> • Oak is a durable timber (1) therefore it will withstand the weather conditions outside (1) meaning it will last a long time (1) • Oak is a tough material (1) therefore it will be able to withstand the knocks and bumps it will be subjected too in its use as a gate (1) meaning it will stay in a good condition (1) • Oak has an attractive colour / is a natural timber (1) therefore it will fit into the natural surroundings of a garden gate (1) and not stick out too much from a visual point of view (1) 	(6)

Question number	Answer	Mark
8 (a)(i)	<p>Any one explanation that includes a reason (1) and a linked justification of that reason (1).</p> <ul style="list-style-type: none"> • Chipboard has a rough / unattractive surface finish (1) which will be improved by sticking a visually attractive / colourful / textured veneer to it (1) • The value of the product is enhanced with the addition of a veneer (1) which means it can be sold for more / the value of the chipboard is increased (1) 	(2)

Question number	Answer	Mark
8 (a)(ii)	<p>Any one explanation that includes a working property (1), plus one linked justification of that property (1) + (1).</p> <ul style="list-style-type: none"> • Dimensionally stable in large / flat / wide sheets (1) which means smaller sections do not have to be glued together (1) saving on time / reducing manufacturing costs (1) • Chipboard is easily machined (1) which means that it can cut / drilled (1) to the exact shape / size and holes drilled for KD fittings (1) • Chipboard has variable density (1) which makes KD fittings an appropriate choice (1) and they can create a strong joint and carry relatively large weights (1) 	(3)

Question number	Answer	Mark
8 (b)	<p>Any two explanations that includes an advantage (1) and a linked justification of that advantage (1).</p> <ul style="list-style-type: none"> • CAM systems will simply repeat the program time after time (1) therefore all pieces will be identical (1) • CAM systems will operate 24/7 (1) therefore productivity output will be high / will meet levels of consumer demand (1) • Designs can be easily adjusted to make LH/RH panels / sizes changed (1) which means new programs / files uploaded / stored / easily retrieved to meet consumer demand (1) • Files can be tessellated / nested using CAM software (1) which means maximum use of material can be realised / waste reduced (1) 	(4)

Question number	Indicative content	Mark
8 (c)	<p data-bbox="355 277 550 309">AO3 (9 marks)</p> <ul data-bbox="355 353 1265 1303" style="list-style-type: none"> • Low cost suitable for low-income groups such as students / people setting up new home • More appealing to younger generation / more contemporary style living • Ability to be purchased / taken home / easily moved in high rise apartment blocks • Relatively cheap and disposable / short life-span / not as durable as traditional furniture / easily replaced with changing trends and fashion / colour • Ability to incorporate lighting / doors / accessories • Modular design / sizing / fixed together to form bigger units • Versatile design / adjustable shelving • Veneer colour / texture can be changed to suit current trends / fashion / changes in taste • Flat-pack nature allows for easy distribution around the world • Using chipboard and veneers helps to reduce the consumption of natural / solid timber which may attract environmentally conscious consumers • The use of KD fittings means products can be distributed flat-pack which reduces the volume / bulk of products being transported • KD fittings allows the product to be taken apart / disassembled at the end of its useful working life allowing separate parts to be recycled into their own material groups • Ability to reuse across different generations / households 	(9)

Level	Mark	Descriptor
	0	
Level 1	1 - 3	<ul style="list-style-type: none"> • Attempts to interrogate and deconstruct information but connections and logical chains of reasoning are flawed. • An unbalanced appraisal of the information/issues, containing judgements that show a limited awareness of the interrelationships between factors or competing arguments. • A conclusion may be presented but it is likely to be generic assertions rather than supported by relevant judgements.
Level 2	4 – 6	<ul style="list-style-type: none"> • Interrogates and deconstructs information and provides some connections and logical chains of reasoning. • A balanced appraisal of the information/issues, containing judgements that show an awareness of the interrelationships between factors or competing arguments. • A conclusion is presented that is partially supported by relevant judgements.
Level 3	7 - 9	<ul style="list-style-type: none"> • Interrogates and deconstructs information and provides sustained connections and logical chains of reasoning. • A well-balanced appraisal of the information/issues, containing judgements that show a thorough awareness of the interrelationships between factors or competing arguments. • A conclusion is presented that is fully supported by relevant judgements.